

North Carolina Emissions Inspection Program



**On Board Diagnostics (OBD II)
Emissions Certification Course
Inspection Procedures**

Lesson Purpose

To familiarize students with the mandates and procedures required for certification as a North Carolina OBD II inspection mechanic.



Opening Statement

This training program is designed to familiarize the students with the mandates and procedures required for certification as an emissions inspection mechanic in North Carolina. For this program to be successful, all stakeholders must develop a complete understanding of the requirements and regulations. While designing this block of instruction, great care was given to ensure all students, regardless of their individual backgrounds, experiences, and education would benefit and gain additional knowledge of the I/M program. Although some of the information discussed in this lesson plan may be basic to the experienced professional, the information provided will be beneficial to all those who attend.

Course Objectives

At the end of this block of instruction, the student will be able to achieve the following objectives.

1. Identify vehicles that require an OBD II inspection.
2. List in writing the fees associated with an OBD II inspection and identify when they apply.
3. Explain when a waiver of the inspection requirements may be issued.
4. Identify the Emissions Control Components installed on vehicles.
5. Successfully pass a written examination with a score of no less than 80%.

Reason for Training

Motor vehicle inspection and maintenance (I/M) programs are an integral part of the effort to reduce mobile sources of air pollution. Despite being subject to the most rigorous vehicle pollution control program in the world, vehicles in the United States still create a substantial amount of carbon monoxide, hydrocarbons, nitrogen oxides, and other pollutants. One reason for this is the fact that the number of vehicle miles traveled on U.S. roads has doubled in the last two decades to 2 trillion miles per year, partially offsetting the technological progress in vehicle emissions control made during that time. Projections of continued growth in vehicle travel necessitate continued emission reduction efforts so air quality goals may be achieved.

Reason for Training (Continued)

Under the Clean Air Act as amended in 1990, the U.S. Environmental Protection Agency (EPA) is pursuing a three-point strategy for reducing emissions from transportation sources. The first two points involve the development and commercialization of cleaner vehicles and cleaner fuels. The third point focuses on in-use control to ensure that cars in customers use are properly maintained. Inspection and Maintenance (I/M) programs are intended to address this third point.



Station Qualifications

An inspection station is a place of business legally licensed by the DMV Commissioner to conduct inspections of motor vehicles as required by North Carolina General Statute. Each Inspection Station must be equipped with the proper equipment and tools to perform inspections, which includes the following.

- a) One jack or lift with a minimum capacity of two tons.
- b) One headlight tester to fit all headlights. (Mechanical, optical, or wall chart)
- c) One workbench.
- d) One creeper.
- e) One tire tread depth gauge (calibrated in 32nds of inch).



Station Qualifications (Continued)

- (f) One Emissions Control Systems Application Manual or current computerized electronic software.
- (g) One approved Emissions Analyzer with current software.
- (h) One active dedicated telephone line (Broadband Connection).

Note : Each licensed inspection station should display the Official Safety and OBD Procedure Posters, station license and fee chart in the waiting room or at the cash register.

Station Qualifications (Additional Equipment)

Inspection stations are not required to conduct inspections on vehicles equipped with after factory window tint. However, if inspections are conducted on these vehicles, the inspection station must have the following optional equipment.

- ▣ One (1) Approved Window Tint Tester



Mechanic Qualifications

An applicant for a license as an emissions inspection mechanic must meet all of the following requirements for initial and continued certification:

1. The applicant must have a license as a safety inspection mechanic in North Carolina.
2. The applicant must have a drivers license that is valid in North Carolina.
3. The applicant must be of good character and have a reputation for honesty and be able to successfully pass a background check as required by the Division. (Applicants who are denied licensing because of prior criminal history will be contacted and have the opportunity to submit documentation to the Licensing Review Board before final determination is made. The applicant will be notified in writing of the outcome of the review board.)

The license of an Emissions Inspector-Mechanic expires every 2 years.

Mechanic Qualifications (Continued)

4. The applicant must successfully complete an eight-hour course approved by the Division that teaches students about the causes and effects of the air pollution problem, the purpose of the emissions inspection program, the vehicle emissions standards established by the United States Environmental Protection Agency, the emissions control devices on vehicles, how to conduct an emissions inspection using equipment to analyze data provided by the on-board diagnostic (OBD) equipment approved by the Environmental Management Commission, and any other topic required by 40 CFR 51.367 to be included in the course.

The logo features the words "KNOW IT ALL" in a bold, italicized, sans-serif font. The letters are white with a black outline and a slight drop shadow. The word "IT" is highlighted in red, and the entire text is set against a black, slanted rectangular background.

Mechanic Qualifications (Continued)

5. The applicant must successfully pass a written examination with a score of no less than 80% correct answers.
6. The applicant must successfully conduct a hands-on test in which you will be required to conduct a safety / emissions inspection of a vehicle with an approved certified emissions analyzer.

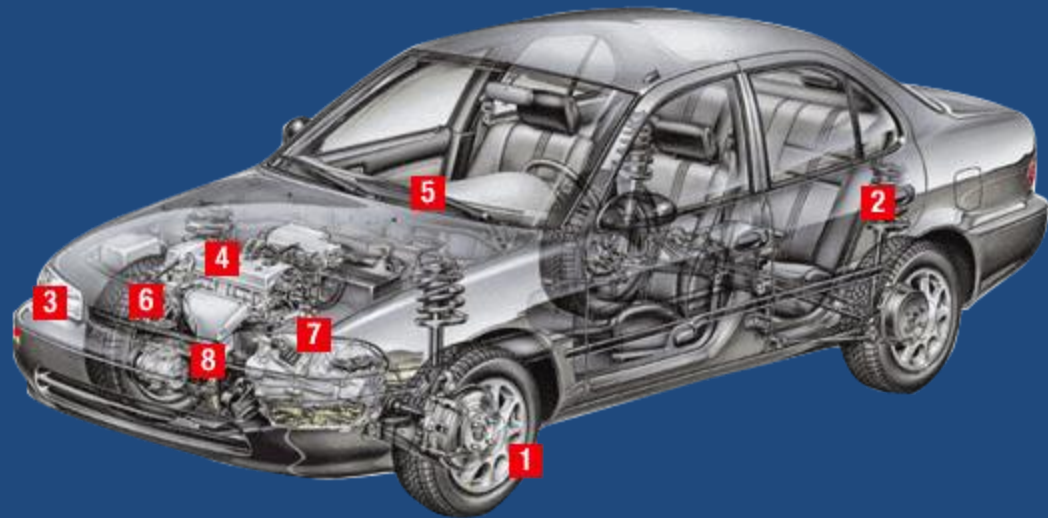

Emissions Analyzers

Before being approved for use, emissions analyzers are subjected to extensive testing and certification by the division of air quality and DMV. The analyzers currently approved for use are listed below in alphabetical order:

Banalogic

Ease Diagnostics

ESP

OPUS



Snap-on (SUN)

SPX

Systech

Worldwide

Cause and Effects of Air Pollution

Air pollution generally refers to gasses and chemicals released by manmade sources such as factories, power plants, cars and trucks. It can cause diseases such as cancer, birth defects, immune diseases, allergies and asthma. It also damages the ozone layer and can erode buildings and lead to soil and water damage.

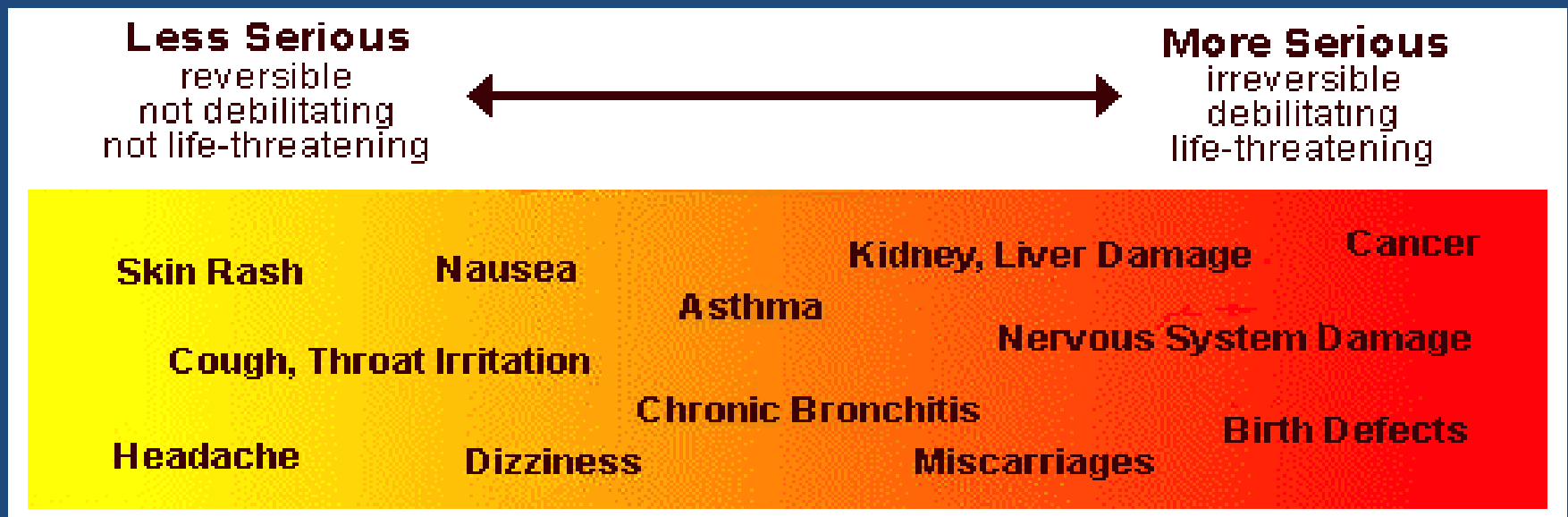

Vehicle Generated Pollutants

Emissions from an individual car are generally low, relative to the smokestack image many people associate with air pollution. However, in numerous cities across the country, the personal automobile is the single greatest polluter as emissions from millions of vehicles on the road add up.

- 1. The Combustion Process:** Gasoline and diesel fuels are mixtures of hydrocarbons, compounds that contain hydrogen and carbon atoms. In a “perfect” engine, oxygen in the air would convert all the hydrogen in the fuel to water and all the carbon in the fuel to carbon dioxide. Nitrogen in the air would remain unaffected. In reality, the combustion process cannot be “perfect”, and automotive engines emit several types of pollutants.

Vehicle Generated Pollutants (Continued)

2. Evaporative Emissions:

Hydrocarbon pollutants also escape into the air through fuel evaporation. With today's efficient exhaust emission controls and gasoline formulations, evaporative losses can account for a majority of the total hydrocarbon pollution from current model cars on hot days when ozone levels are highest. Evaporative emissions occur several ways:

- a) **Diurnal:** Gasoline evaporation increases as the temperature rises during the day, heating the fuel tank and venting gasoline vapors.
- b) **Running Losses:** The hot engine and exhaust system can vaporize fuel when the engine is running.

Vehicle Generated Pollutants (Continued)

- c) Hot Soak: The engine remains hot for a period of time after it is turned off, and gasoline evaporation continues when the car is parked.
- d) Refueling Losses: Gasoline vapors are always present in fuel tanks. These vapors are forced out when the tank is being filled with liquid fuel.

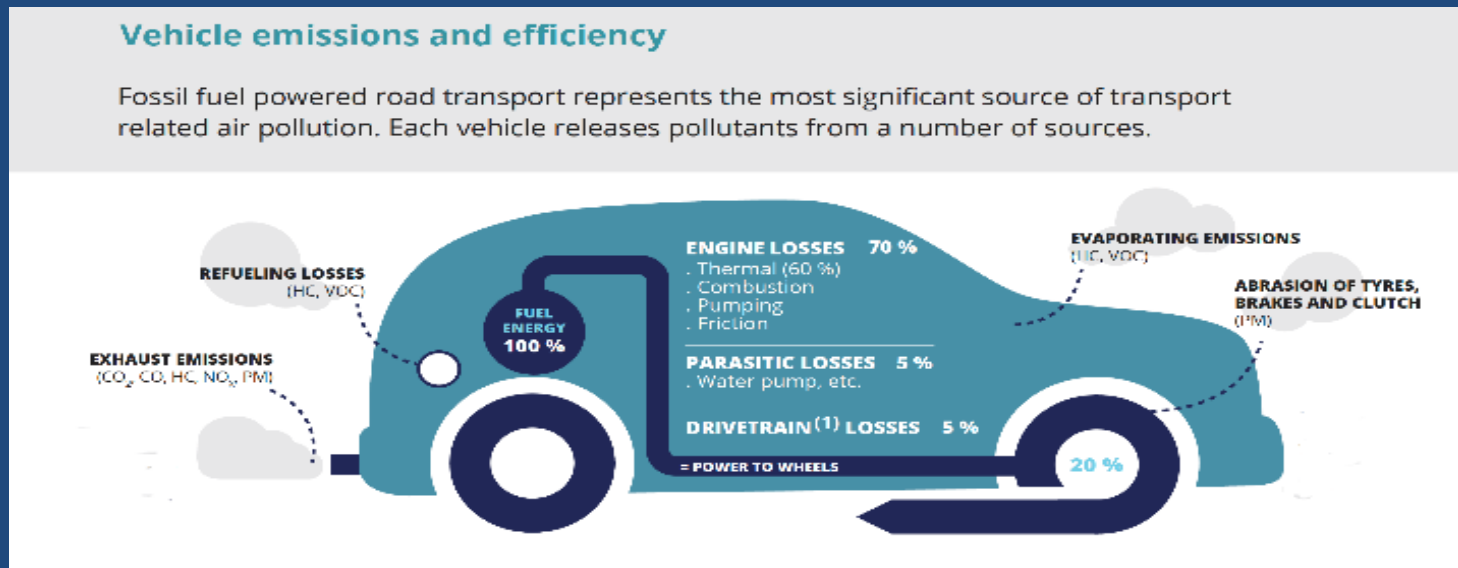

Vehicle Generated Pollutants (Continued)

3. Tailpipe Emissions:

Hydrocarbon emissions result when fuel molecules in the engine do not burn or only burn partially. Hydrocarbons react in the presence of nitrogen oxides and sunlight to form ground – level ozone, a major component of smog.



Purpose of the Inspection Program

During the last two decades there have been considerable emission control development efforts on the part of both vehicle manufacturers and the federal government. As a result, passenger cars and light-duty trucks produced in recent years emit significantly lower emissions than their predecessors, provided they are properly operating. A large body of evidence, however, indicates that current generation vehicles are not all operating properly during actual use. Emission related malfunctions do not always cause an outward indication of a problem (poor drivability or decreased fuel economy) and are sometimes difficult to detect and repair.

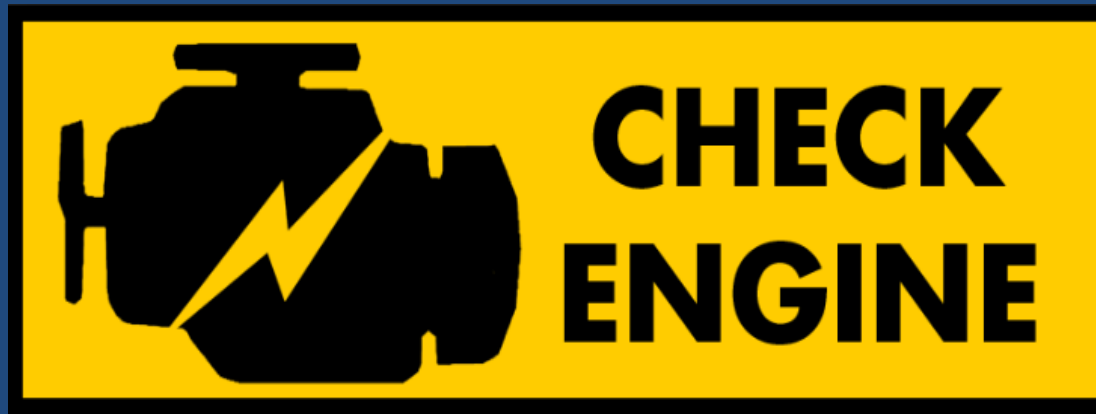

Purpose of the Inspection Program (Continued)

The purpose of the Inspection & maintenance (I/M) program is:

1. To identify poorly maintained or defective vehicles that are being operated on NC highways;
2. To ensure vehicles are properly repaired to meet the appropriate use standards so as to reduce emissions; and
3. To identify vehicles that may have tampered emission controls.

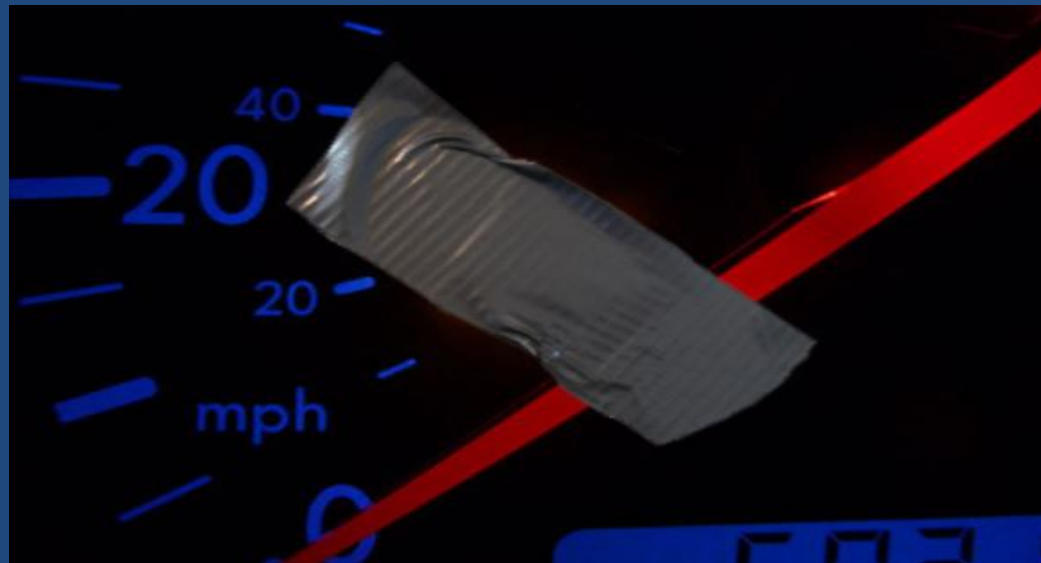

Vehicle Emissions Standards

1. Federal Test Procedure Standards are set to ensure vehicles meet the regulations imposed by the Clean Air Act. They define and prescribe standards applicable to the emissions of any air pollutant from any class or classes of motor vehicles or motor vehicle engines.
2. These regulations and standards are applicable to vehicles and engines for their useful life upon verification of the vehicle's compliance.
3. The EPA is required to test any emissions control system incorporated in a motor vehicle or motor vehicle engine submitted to them, in order to determine if it will conform to the standards required to be prescribed under section 202 (b) of the Clean Air Act.

Vehicle Emissions Standards (Continued)

4. A certificate of conformity is issued if the EPA determines that the manufacturer has established that any emissions control device, system, or element of design installed on, or incorporated in, such vehicle or engine conforms to the applicable requirements.
5. OBD II systems are designed to monitor emissions-related components for malfunctions or deterioration that renders the vehicles incapable of complying with the emissions standards established by the manufacturer and certified by the EPA for each individual vehicle.

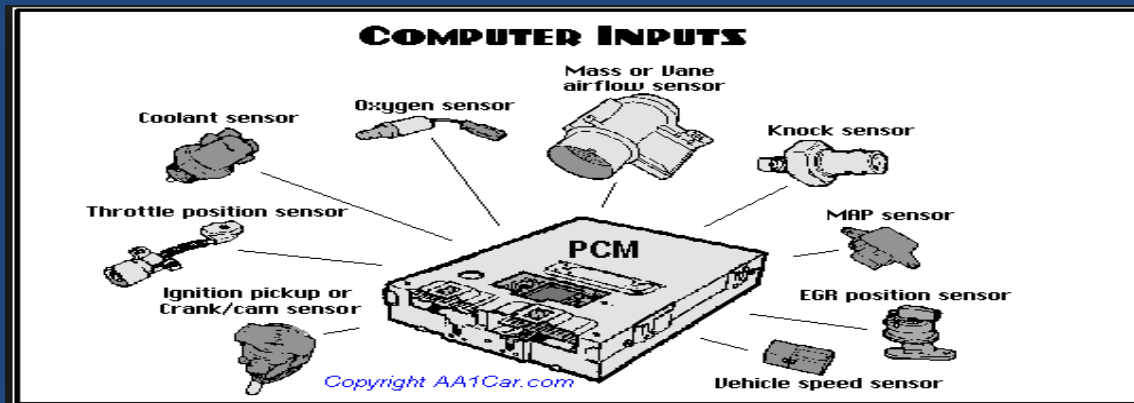

Vehicle Emissions Standards (Continued)

6. A malfunction indicator lamp (MIL) located in the dashboard of the vehicle is required to be illuminated when the OBD system detects malfunctions or deterioration of the emissions components.
7. The purpose of the MIL is to inform the vehicle operator of the need for service when the vehicle deteriorates to the point where the vehicle emissions could rise above 1.5 times the Federal Test Procedure standards.



Emissions Control Devices

All 1996 and newer vehicles are equipped with one or more of the following emissions control devices as required by the manufacturer.

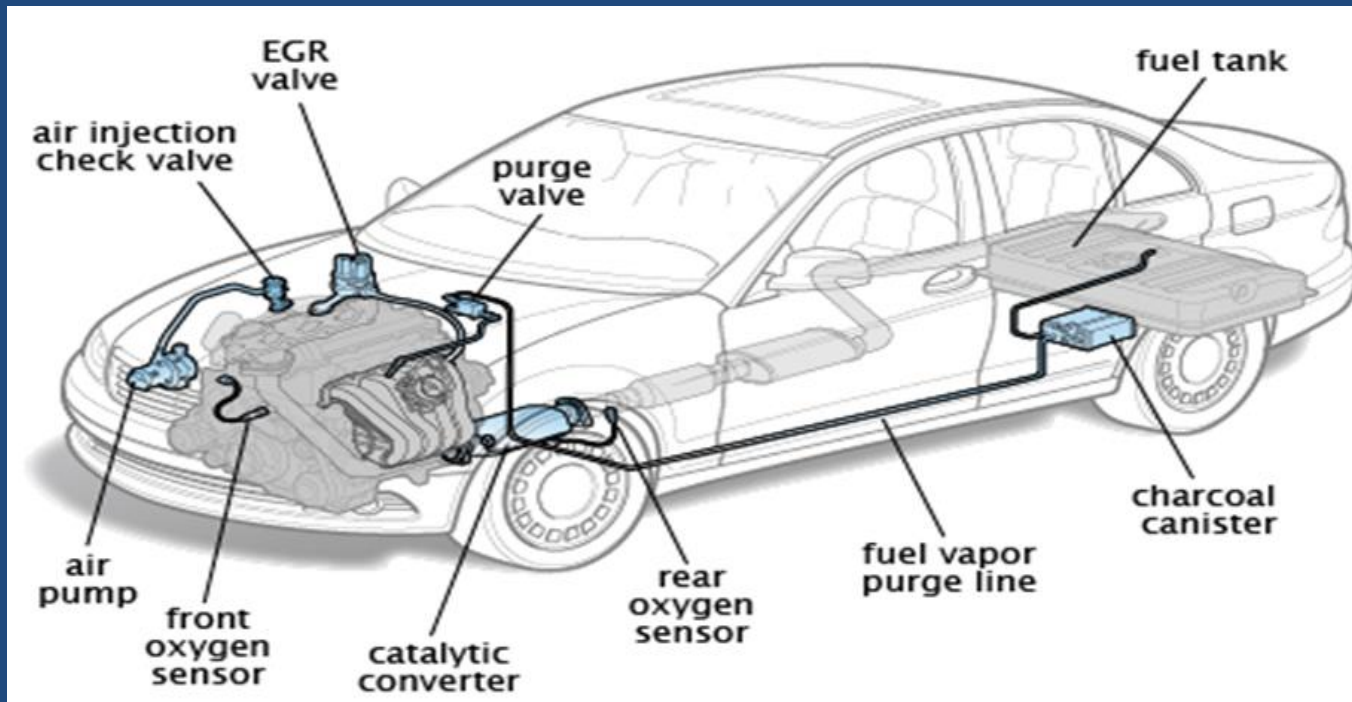

Emissions Control Devices (Continued)

a) Catalytic Converter

The Catalytic Converter burns any remaining hydrocarbons and carbon monoxide emissions that pass into the exhaust system. It contains a catalyst substance of platinum, palladium, rhodium, cerium or a mixture of these materials that heat to extreme temperatures of approximately 1400 degrees to ignite the emissions and change them into harmless carbon dioxide and water.

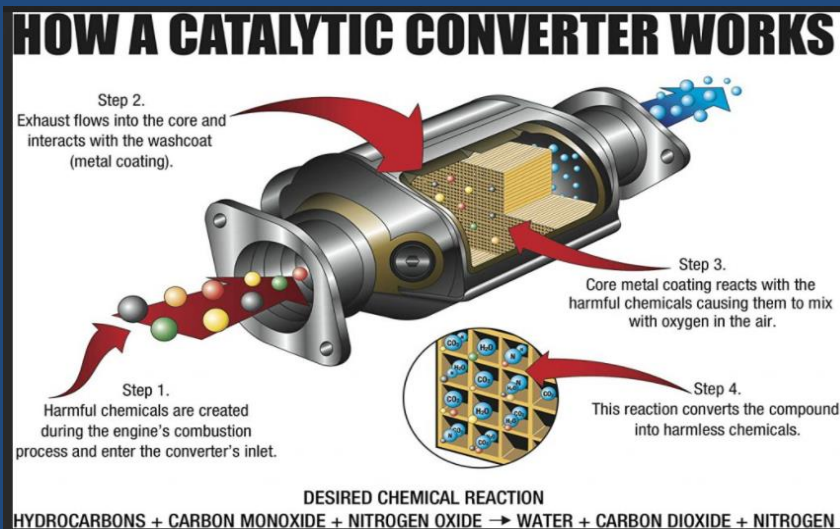

Emissions Control Devices (Continued)

b) Unleaded Gas Restrictor:

The Unleaded Gas Restrictor or Fuel Restrictor reduces and restricts the filler neck to a size that permits filling by unleaded gasoline sized nozzles only. If altered or removed, the catalytic converter and unleaded gas restrictor must be replaced before the vehicle can pass inspection. Mechanics should remember that some newer model vehicles are being manufactured without the unleaded gas restrictor.



Emissions Control Devices (Continued)

c) Air Injection System:

The air injection system (AIS) is designed to introduce clean air into the engine exhaust as it exits the exhaust manifold or exhaust headers. Exhaust gases are at their hottest as they leave the combustion chambers, introducing oxygen to the exhaust at this point allows continued burning of the fuel mixture as it travels down the exhaust system and ultimately out the tailpipe. There are two types of air injection systems.

1. Pulse Air Injected Recirculation (P.A.I.R) uses the normal pulsing from the exhaust valve opening and closing and does not require a pump.
2. Pump Types are externally mounted and are either electrical or belt driven.

Emissions Control Devices (Continued)

P.A.I.R.

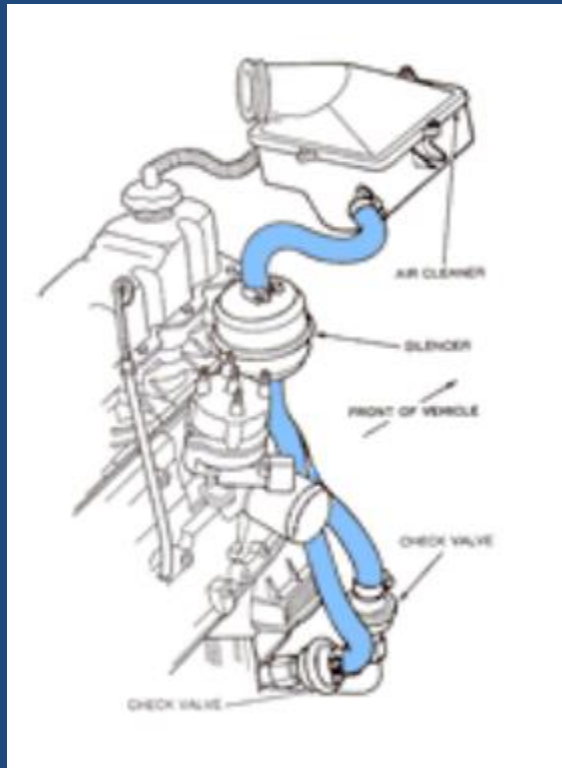

PUMP

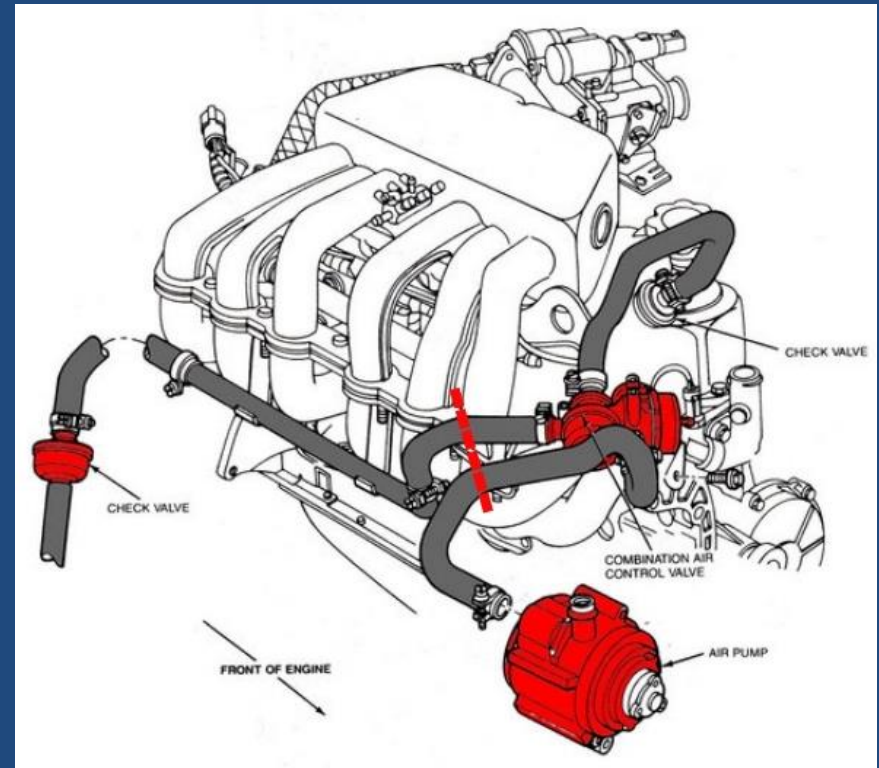

Emissions Control Devices (Continued)

d) Exhaust Gas Recirculation System:

The Exhaust Gas Recirculation System injects burned exhaust gases into the engine to lower combustion temperatures and prevents the formation of Nitrogen Oxides. The EGR valve is connected with either a vacuum hose or electrical connection and they must be connected to pass the inspection. The EGR is normally located on or near the intake manifold.



Emissions Control Devices (Continued)

e) Positive Crankcase Ventilation:

The Positive Crankcase Ventilation System recirculates engine crankcase fumes back into the combustion chamber. The PCV system must be sealed in order to be effective.



Emissions Control Devices (Continued)

f) Thermostatic Air Cleaner System:

The Thermostatic Air Cleaner System maintains a constant temperature of the air entering the engine for improved combustion and performance in cold weather. The warm air helps vaporize fuel and reduce Hydrocarbons and Carbon Monoxide. Two components (only) can be missing from the TAC and it will still pass the inspection. They are the snorkel hose and the air filter.

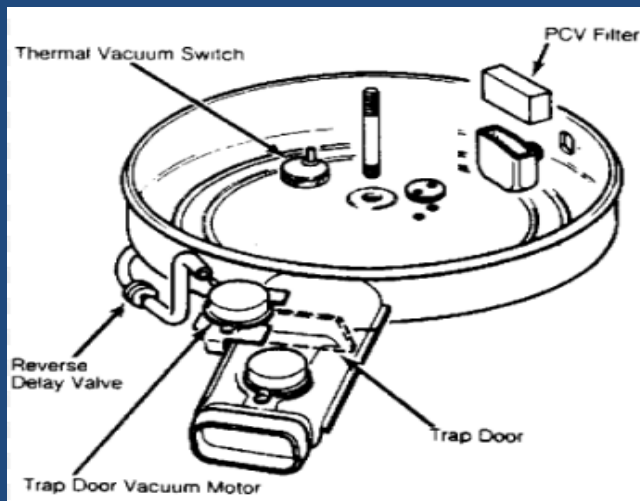

Emissions Control Devices (Continued)

g) Evaporative Emissions Control System:

The Evaporative Emissions Control System is a closed vent system that stores fuel vapors and prevents them from entering the atmosphere. It consists of the Charcoal Canister, the Canister Vacuum Lines, the Vacuum and Pressure Relief Valve, the Purge System, the Fuel Tank and the Gas Cap.

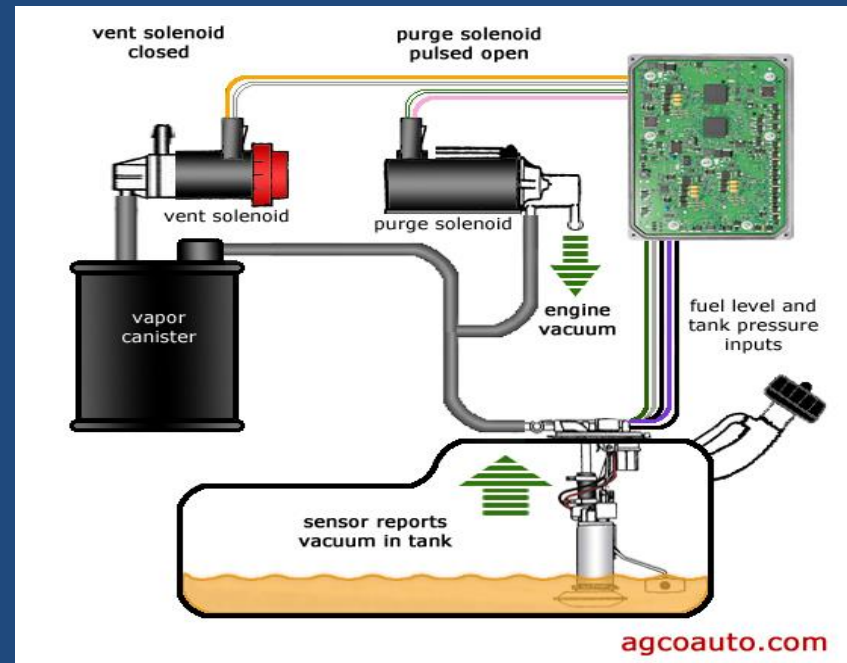
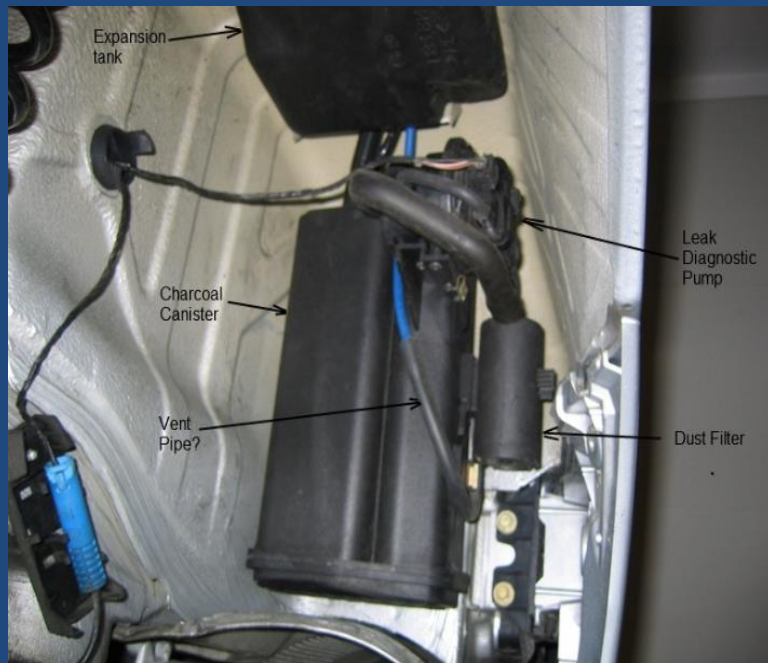

Emissions Control Devices (Continued)

h) Oxygen Sensor:

The Oxygen Sensor monitors the amount of oxygen in the exhaust gases. Most manufacturers use more than one oxygen sensor to perform this task. To pass a vehicle inspection, a technician must locate all installed sensors and verify they are connected. The sensors are normally located in the exhaust manifold and/or the exhaust pipes before and/or after the catalytic converter.



Emissions Control Devices (Continued)

As part of the tamper inspection, a visual inspection of each component is required. To determine which components are installed on the vehicle, the inspection mechanic should refer to the Emissions Control Label located within the engine compartment. Additional information may also be obtained from the Emissions Control Applications Manual and/or various third-party computer programs. However, in any case where discrepancies of installed components exist, the information provided by the Emissions Control Label should always take precedence. (If available)

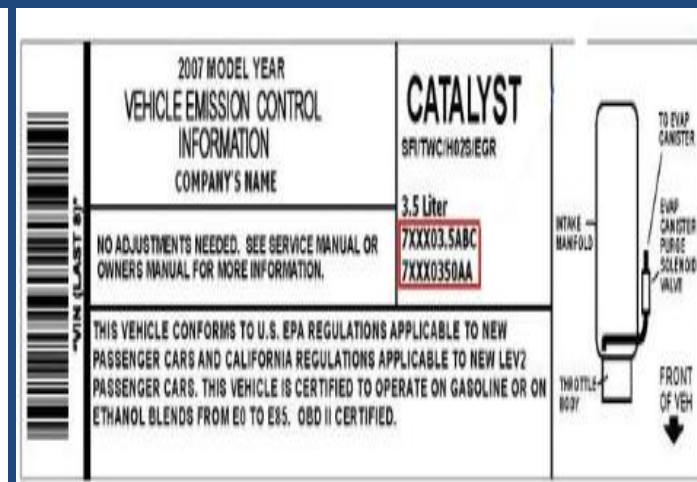

Malfunction Indicator Lamp (MIL)

The Malfunction Indicator Lamp (MIL) is an indicator of the internal status of a car engine. It is found on the instrument console of most automobiles and is either red or amber in color. The MIL can be the shape of an engine, or the words spelled out as “Check Engine” or “Service Engine Soon”. If the MIL is illuminated, the vehicle must be repaired before it will pass the inspection. However, it is imperative that customers are never refused inspections because the light is illuminated. As indicated in North Carolina Administrative Code, the inspection station is required to inspect any vehicle presented for inspection.























Malfunction Indicator Lamp (MIL) (Continued)

Inspection mechanics should note that some vehicles have a Service light in addition to the Malfunction Indicator Lamp. The service light normally indicates that the vehicle is due for some type of maintenance cycle. The inspection mechanic should use caution not to confuse the service light with the MIL.



Safety Symbols.
These symbols might appear as different colours but they should be looked at when it is safe.

 Seat belt not on	 Airbag deactivated	 Airbag warning	 Press clutch pedal	 Service required	 Parking brake light	 ABS warning	 Brakelight warning	 Distance warning	
 Automatic gearbox warning	 Trailer tow hitch warning	 Engine/emissions warning	 Catalytic converter warning	 Air suspension warning	 Fuel filter warning	 Frost warning	 Suspension dampers	 Stability control off	 Steering lock warning
		 Tire pressure low	 Brake pad warning	 Power steering warning light					

Diagnostic Trouble Codes (DTC)

Diagnostic Trouble Codes provide a simple description of a problem found by the OBD II system. They will be captured by the inspection analyzer and printed on page 2 of the OBD II Failure Report. It is imperative that this page be provided to the customer at the time of failure. However, the diagnostic trouble codes indicated on the report simply reflect the vehicle's condition at the time of testing and are not intended to take the place of diagnostics and repairs by a qualified repair technician.



SERVICE ENGINE SOON

CHECK

CHECK ENGINE

Why Check Engine light comes on?

© Samarins.com

P0181	Fuel Temperature Sensor Circuit Range or Perf	P0320	Ignition or Distributor Engine Speed Input Circuit Problem
P0182	Fuel Temperature Sensor Circuit Low Input	P0321	Ignition or Distributor Engine Speed Input Circuit Range or Perf
P0183	Fuel Temperature Sensor Circuit High Input	P0322	Ignition or Distributor Engine Speed Input Circuit No Signal
		P0325	Knock Sensor 1 Circuit Problem
P0201	Injector Circuit Problem — Cylinder 1	P0326	Knock Sensor 1 Circuit Range or Performance
P0202	Injector Circuit Problem — Cylinder 2	P0327	Knock Sensor 1 Circuit Low Input
P0203	Injector Circuit Problem — Cylinder 3	P0328	Knock Sensor 1 Circuit High Input
P0204	Injector Circuit Problem — Cylinder 4	P0330	Knock Sensor 2 Circuit Problem
P0205	Injector Circuit Problem — Cylinder 5	P0331	Knock Sensor 2 Circuit Range or Performance
P0206	Injector Circuit Problem — Cylinder 6	P0332	Knock Sensor 2 Circuit Low Input
P0207	Injector Circuit Problem — Cylinder 7	P0333	Knock Sensor 2 Circuit High Input
P0208	Injector Circuit Problem — Cylinder 8	P0335	Crankshaft Position Sensor Circuit Problem
P0209	Injector Circuit Problem — Cylinder 9	P0336	Crankshaft Position Sensor Circuit Range or Performance
P0210	Injector Circuit Problem — Cylinder 10	P0337	Crankshaft Position Sensor Circuit Low Input
P0211	Injector Circuit Problem — Cylinder 11	P0338	Crankshaft Position Sensor Circuit High Input
P0212	Injector Circuit Problem — Cylinder 12	P0400	Exhaust Gas Recirculation Flow Problem
P0213	Cold Start Injector 1 Problem	P0401	Exhaust Gas Recirculation Flow Insufficient Detected
P0214	Cold Start Injector 2 Problem	P0402	Exhaust Gas Recirculation Flow Excessive Detected
		P0405	Air Conditioner Refrigerant Charge Loss
P0300	Random Misfire Detected	P0410	Secondary Air Injection System Problem
P0301	Cylinder 1 Misfire Detected	P0411	Secondary Air Injection System Insufficient Flow Detected
P0302	Cylinder 2 Misfire Detected	P0412	Secondary Air Injection System Switching Valve or Circuit Problem
P0303	Cylinder 3 Misfire Detected	P0413	Secondary Air Injection System Switching Valve or Circuit Open
P0304	Cylinder 4 Misfire Detected	P0414	Secondary Air Injection System Switching Valve or Circuit Shorted
P0305	Cylinder 5 Misfire Detected	P0420	Catalyst System Efficiency Below Threshold (Bank 1)
P0306	Cylinder 6 Misfire Detected	P0421	Warm Up Catalyst Efficiency Below Threshold (Bank 1)
P0307	Cylinder 7 Misfire Detected	P0422	Main Catalyst Efficiency Below Threshold (Bank 1)
P0308	Cylinder 8 Misfire Detected	P0423	Heated Catalyst Efficiency Below Threshold (Bank 1)
P0309	Cylinder 9 Misfire Detected	P0424	Heated Catalyst Temperature Below Threshold (Bank 1)
P0310	Cylinder 10 Misfire Detected	P0430	Catalyst System Efficiency Below Threshold (Bank 2)
P0311	Cylinder 11 Misfire Detected	P0431	Warm Up Catalyst Efficiency Below Threshold (Bank 2)
P0312	Cylinder 12 Misfire Detected	P0432	Main Catalyst Efficiency Below Threshold (Bank 2)

Data Link Connector (DLC)

The Data Link Connector (DLC) allows communication between the emissions analyzer and the vehicle's OBD II system. Its size, shape and locations have been standardized by the EPA. In accordance with this standardization, the DLC is most commonly located on the driver's side but may extend to the console or passenger side of the vehicle in some cases. If the DLC is missing or has been tampered with, the vehicle will fail the inspection. If the DLC cannot be located or is inaccessible, the inspection must be aborted.

Attempt to verify there is no OBD simulator installed on the vehicle. A simulator installed to produce erroneous readings should result in a failure.

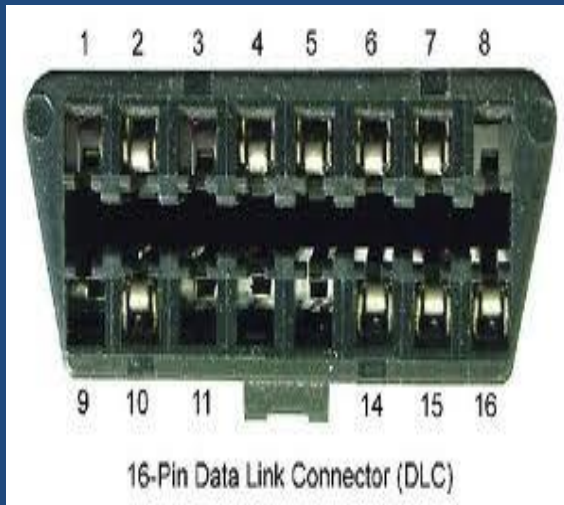

Readiness Monitors

To help ensure the OBD II system is working properly, readiness codes are used to indicate whether or not monitored emissions control system have been tested by the OBD II system. Each emissions control device has its own monitor and related readiness code. If any of the readiness codes are set to “not ready” or “not complete”, the OBD II system has not yet completed testing of that particular component or system. A component failure may exist, but this has not yet been identified because the system testing has not been completed.

Test	Supported	Complete	This Cycle
Misfire monitoring	Yes	Yes	Yes
Fuel system monitoring	Yes	Yes	Yes
Comprehensive compone...	Yes	Yes	Yes
Catalyst monitoring	No	-	
Heated catalyst monitoring	No	-	
Evaporative system monit...	No	-	
Secondary air system moni...	No	-	
A/C system monitoring	No	-	
Oxygen sensor monitoring	No	-	
Oxygen sensor heater mo...	No	-	
EGR system monitoring	No	-	

Readiness Monitors (Continued)

A vehicle may have any combination of the following monitors installed; this is determined by the manufacturer. However, all vehicles are equipped with the Misfire, Fuel System and Comprehensive Component Monitors, which run continuously.

Misfire	Catalyst	Secondary Air System
O2 Sensor Heater	Fuel System	Heated Catalyst
A/C System	EGR System	Comprehensive Component
Evaporative System	O2 Sensors	

Readiness Monitors (Continued)

- ▣ Vehicles are allowed to complete the OBD II inspection with one monitor set as not ready.



- ▣ When a not ready rejection occurs, the customer should be informed that the monitors may set to ready through the course of normal driving over the next few days, but in some cases, it may be necessary to conduct the manufacturers specific drive cycle. Under no circumstances should the customer ever be instructed to drive a specific mileage unless the mileage is a part of the specific drive cycle instructions for that vehicle. Although not required, inspection stations are encouraged to provide the specific drive cycle to the customer if available and requested.

OBD II Subject Vehicles

19A NCAC 03D .0543 INSPECTION PROCEDURE FOR EMISSIONS EQUIPMENT

(a) In accordance with G.S. 20-183.2, vehicles required to receive a State safety inspection are also subject to an emission inspection if it is propelled or has the ability to be propelled by a gasoline-powered motor vehicle, registered or based in an emission county, and meets the following criteria:

1. All vehicles within 20 model years of the current model year, light duty gasoline operated vehicles registered in one of the 19 emissions counties.

Alamance	Buncombe	Cabarrus	Cumberland
Davidson	Durham	Forsyth	Franklin
Gaston	Guilford	Iredell	Johnston
Lincoln	Mecklenburg	New Hanover	Randolph
Rowan	Union	Wake	

OBD II Subject Vehicles

2. All vehicles within 20 model years of the current model year, light duty gasoline operated vehicles registered in one of the 19 emissions counties that are part of a fleet of vehicles operated primarily in an emissions county.
3. All vehicles within 20 model years of the current model year, light duty gasoline operated vehicles registered in one of the 19 emissions counties that are offered for rent in an emissions county.
4. All vehicles within 20 model years of the current model year, light duty gasoline operated vehicles registered in one of the 19 emissions counties and light duty gasoline operated vehicles offered for sale by a dealer in an emissions county.

OBD II Subject Vehicles

5. All vehicles within 20 model years of the current model year, light duty gasoline operated vehicles operated on a federal installation located in an emissions county. This does not include tactical military vehicles. Vehicles operated on a federal installation include those that are owned or leased by employees of the installation and those owned or operated by the federal agency that conducts business at the installation, regardless of where the vehicle is registered.



Exceptions to the OBD Emissions Inspection

The following vehicles are exempt from OBD II testing:

1. New Vehicles: (3/70,000 Exemption includes new vehicles)

New Vehicles are defined as motor vehicles that have never been the subject of a completed, successful or conditional sale that was subsequently approved other than between new motor vehicle dealers, or between manufacturer and dealer of the same franchise. However, a new motor vehicle that has been leased or rented, or offered for lease or rent, is subject to an emissions inspection when it is either;

- a) Leased or rented, or offered for lease or rent, for 12 months or more.
- b) Sold to a customer – purchaser.

NO Emission Inspection Needed

Exceptions to the OBD Emissions Inspection

2. All Motorcycles – MUV's and Low Speed vehicles.
3. Property-hauling vehicles registered with farm tags.
4. Vehicles that exceed 8500 pounds as indicated by the “Gross Vehicle Weight Rating”. This rating commonly comes from the vehicles door jam but should never be obtained from the registration card.
5. Privately owned, non-fleet motor home or house car, as defined in G.S. 20-4.01 (27) d2, that is built on a single chassis, has a gross vehicle weight of more than 10,000 pounds, and is designed primarily for recreational use.

NO Emission Inspection Needed

Exceptions to the OBD Emissions Inspection

6. 3-Year and 70,000 Miles Exemption:

As of April 1, 2015, emission inspections are waived for all vehicles that are within the three most recent model years **AND** have **LESS THAN 70,000** miles. Only a safety inspection is required.

3



NO Emission Inspection Needed

SL2023-134 Changes (Upon approval from the EPA)

REDUCE EMISSIONS INSPECTIONS REQUIREMENTS

SECTION 12.7.(a) G.S. 20-183.2(b) reads as rewritten:

"(b) Emissions. – A motor vehicle is subject to an emissions inspection in accordance with this Part if it meets all of the following requirements:

(3) ~~It is (i) a vehicle with a model year within 20 years of the current year and older than the three most recent model years or (ii) a vehicle with a model year within 20 years of the current year and has 70,000 miles or more on its odometer.~~

(3a) It is a vehicle with a model year within 20 years of the current year and earlier than the 2017 model year.

SECTION 12.7.(b) G.S. 143-215.107A(c) reads as rewritten:

"(c) Counties Covered. – Motor vehicle emissions inspections shall be performed in the following counties: ~~Alamance, Buncombe, Cabarrus, Cumberland, Davidson, Durham, Forsyth, Franklin, Gaston, Guilford, Iredell, Johnston, Lincoln, Mecklenburg, New Hanover, Randolph, Rowan, Union, and Wake.~~Mecklenburg County."

Changes will only occur when approved by the EPA and implemented by the State. Continue present requirements until notification from the State occurs.

Pre-Inspection Requirements

The OBD II mechanic should always follow the below procedure before attempting the inspection.

1. Verify the Vehicle Identification Number (VIN) listed on the registration card matches the VIN listed on the vehicle. If they do not match, the customer should be directed to the Local License & Theft Bureau for assistance. If no registration card is available, continue with the inspection with the information obtained from the vehicle.
2. Verify that the license Plate on the vehicle matches the license plate listed on the registration card. If no registration plate or card is available, continue the inspection with the information obtained from the vehicle.

Pre-Inspection Requirements (Continued)

The OBD II mechanic should always follow the below procedure before attempting the inspection.

3. Have all occupants leave the vehicle.



4. Drive the vehicle into the inspection bay.



Entering Vehicle Data

The Inspection Procedure is programmed into your analyzer and may vary slightly from the instructions in your lesson plan. In all cases where a discrepancy exist, you should follow the prompts detailed on your inspection analyzer.

1. From the Main Menu, Select “State Inspection”.



2. Select “Safety & Emissions Inspection”.

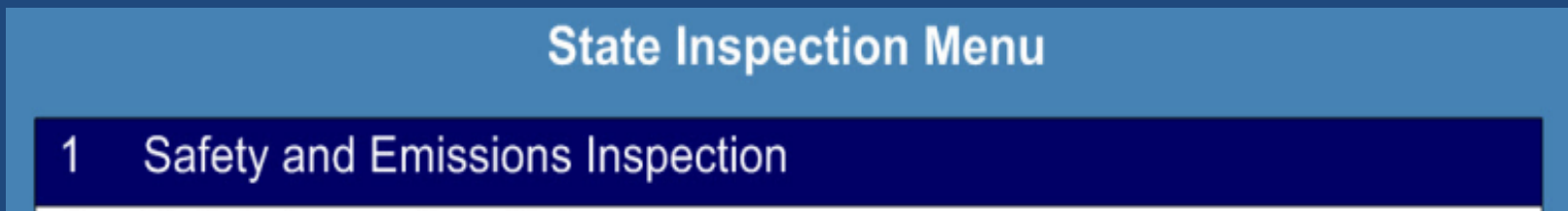

Entering Vehicle Data

3. Enter your mechanics license number and access code.

Please Scan or Enter your Inspector-Mechanic License ID Number.

Please Enter your access code.

(Remember, this information is private and should never be disclosed to anyone!)



Entering Vehicle Data

4. Using the bar code scanner, enter the vehicle identification number (VIN) of the vehicle being tested into the analyzer. If manually entered, you will be prompted to re-enter the information. Verify that the information in the computer matches the registration card before continuing.

**Please scan the Bar Code on the DMV
Registration Card or enter the VIN using the
keyboard**



Entering Vehicle Data

5. Manually enter the complete license plate number and when prompted, enter the complete license number again.

If conducting the inspection for a motor vehicle dealer, enter the dealer number, followed by a “D” (example: 12345D) as the license plate number. If no license plate, enter “NONE”.

Please enter the vehicle license plate number

(Dealer Number followed by “D” not the dealer license plate number)

Entering Vehicle Data

6. Select either “North Carolina” “Out of State” or “Unknown” for the vehicles current registration state.

<input type="radio"/>	N	Vehicle is registered in North Carolina
<input type="radio"/>	O	Vehicle is currently registered Out-of-State
<input type="radio"/>	U	Current Vehicle Registration is unknown

7. If conducting an inspection for a motor vehicle dealer, you will be prompted for the “Dealer Identification Number”. Obtain this number from the dealership that currently owns the vehicle and enter it in the space provided. Immediately following the number, place the letter “D” as the last character, without the letter “D”, the computer will reject all entries.

Entering Vehicle Data

8. If no match of the vehicle is found in the state vehicle information databases, the computer will prompt you for the owner's information. If you see this prompt, completely fill out the information requested.

Please enter the following vehicle owner information

First Name:

Last Name:

Street Address:

City:

ZIP Code:

Entering Vehicle Data

9. Select the county in which the vehicle is registered from the list provided.

County Selection List

- | | |
|-----------|--------------|
| 11 | AVERY |
| 13 | BEAUFORT |
| 15 | BERTIE |
| 17 | BLADEN |
| 23 | BURKE |
| 21 | BLINCOMBE |

10. Select the vehicle body style from the list provided.

Vehicle Body Style

- | | |
|----------|-----------------------|
| 1 | Sedan |
| 2 | Station Wagon |
| 3 | Pickup |
| 4 | Sport Utility Vehicle |
| 5 | Minivan |
| 6 | Full Size Van |
| 7 | Motor Home |
| 8 | Bus |
| 9 | Heavy Duty Truck |
| 10 | Trailer |
| 11 | Motorcycle |

Entering Vehicle Data

11. Respond to the Gross Vehicle Weight Rating question. If the gross vehicle weight rating exceeds 8500 pounds, the vehicle will receive a safety only inspection. (If you select “Yes, the **GVWR** is greater than 8500 pounds, you will be prompted to enter the GVWR as indicated on the vehicle. The GVWR is commonly located on the vehicle’s driver’s doorpost but should never be taken from the registration card.

Is the gross vehicle weight rating (GVWR) of this vehicle in excess of 8500 pounds? Y/N

Entering Vehicle Data

12. Select the fuel type from the list provided. If the vehicle operates on gasoline at anytime during the course of operation, select “G” for gasoline.

Fuel Type

- G Gasoline
- B BI-Fuel
- P Liquid Propane Gas (LPG) Only
- N Liquid/Compressed Natural Gas (LNG/CNG) Only
- D Diesel Fuel**
- E Electric Power
- H Hybrid (Gasoline-capable)
- I Hybrid (Non-Gasoline)
- O Other
- F Fuel Cell Vehicles

Entering Vehicle Data

13. Enter the four-digit vehicle model number.
14. Enter the odometer reading in miles. (Do not enter the tenths digit) If the odometer reading is not available (broken), enter zeros (0) in the space provided and continue with the inspection.
15. Enter the number of cylinders.
16. Enter the Engine Displacement and indicate “Centimeters, Liters, or Inches”.
17. Indicate if the vehicle has dual exhaust or single.

Entering Vehicle Data

Vehicle Model Information

Enter Vehicle model year (4 digits):

Vehicle Odometer Reading: (do not enter tenths):

Number of Cylinders (R for Rotary Engines):

Engine Displacement:

Measured in (L)iters, Cubic (C)entimeters, Cubic (I)nches.

Does Vehicle have dual exhaust? Y/N:

Data Entry Error, will not allow past this field until correct value is entered.

Entering Vehicle Data

18. Select the vehicles type as “Domestic or Foreign” and then enter the vehicle make as shown on the registration card. If the make does not appear on the motor vehicle list provided, select “None of the Above” (Normally located at the bottom of the list).

Vehicle Make Category

- | | |
|---|--------------------------------------|
| 1 | Domestic Light Duty Motor Vehicle |
| 2 | Foreign Light Duty Motor Vehicle |
| 3 | Heavy Duty Motor Vehicle |
| 4 | Select a Make not on the above lists |

Entering Vehicle Data

19. Ensure the information is correct as indicated. If not, go back and correct before proceeding.

Vehicle Information Summary

Make:	DODG
Model Year:	2007
Fuel Type:	Gasoline
Body Type:	Sedan
County:	WAKE

Conducting the OBD Inspection

The inspection procedure is programmed into your analyzer and may vary slightly from the instructions in this lesson plan. In all cases, you should follow the prompts on your inspection analyzer.

1. Turn the engine off and put the key in the “off/lock” position.

Turn the key to “OFF” position.

Press ‘Enter’ to continue

Conducting the OBD Inspection

2. Conduct the Key On - Engine Off test. Turn the ignition on but do not start the vehicle. Determine whether the MIL lamp illuminates. If unsure, cycle the key off, wait 10 seconds and reattempt. You may be required to remove the key before proceeding with a reattempt. **Do not proceed with the inspection until you have determined the status of the MIL lamp.**

Perform the “KEY ON, ENGINE OFF” (KOEO) check to determine if the instrument panel malfunction indicator light (MIL) turns on when the ignition key is turned to the “KEY ON, ENGINE OFF” position.

Does the MIL turn on when the key is placed in the “KEY ON, ENGINE OFF” position?

“Y” - YES, THE MIL TURNS ON.
“N” - NO, THE MIL DOES NOT TURN ON.

When the malfunction indicator light (MIL) turns on, it will either display “SERVICE ENGINE SOON”, “CHECK ENGINE”, the word “CHECK” along with the international engine symbol, or some combination of these depending on the vehicle make.

Conducting the OBD Inspection

3. Locate the vehicle's OBD II Diagnostic Link Connector and attach the analyzer's OBD II port to the vehicle.

Locate the vehicle's OBDII diagnostic link connector and attach the NCAS OBDII port to the vehicle connector. Leave the engine off for at least 12 seconds.

Press any key to continue.

- a) If the connector cannot be located and there is no evidence of a tamper, the test should be aborted. You should advise the customer that you couldn't continue with the test and have them seek assistance elsewhere. If this occurs, you cannot charge for this inspection attempt.
- b) If there is evidence that the connector was there, but has been tampered, the vehicle will fail the OBD II inspection, and the connector must be repaired or replaced before the inspection can be completed.

Conducting the OBD Inspection

4. When prompted by the analyzer, start the vehicle and press “enter” to continue. (Failure to start the vehicle when required may result in a false pass or fail of the vehicle).

Start Engine

Press ‘Enter’ to continue

5. The analyzer will attempt communication with the vehicle. If communication occurs, the results of the OBD II inspection will be displayed and the analyzer will prompt you to continue with the safety and tamper portion of the inspection. If communications fails, the analyzer will re-attempt communication two more times. If this occurs, do not abort the test!

Conducting the OBD Inspection

OBDII Inspection in Process. Please Wait

OBDII portion of the inspection is completed.

Please remove the DLC connector from the vehicle.

Press 'Enter' to continue

Conducting the OBD Inspection

6. Proceed with the safety and tamper portion of the inspection.

Headlights:	P
Parking Lights:	P
Tail Lights:	P
Beam Indicator Light/Switch:	F
License Plate Light:	F
Stop Lights:	F
Direction Signals:	F
Horn:	P
Windshield Wiper:	P
Rear View Mirrors:	P
Foot Brake:	X
Emergency Brake:	
Steering Mechanism:	
Tires:	
Exhaust System:	
Clearance Lights (Bus, Trucks, Trailers):	
Reflectors:	
Window Tinting:	

Catalytic Converter:	P
Air Injection System:	P
PCV Valve:	P
Unleaded Gas Restrictor:	E
Exhaust Gas Recirculation (EGR) Valve:	F
Thermostatic Air Control:	P
Evaporative Emissions System:	P
Oxygen Sensor:	P
Gasoline Tank Cap:	

Conducting the OBD Inspection

7. Print the inspection receipt, sign and provide to the customer.

STATE OF NORTH CAROLINA VEHICLE INSPECTION RECEIPT/STATEMENT SAFETY AND EMISSIONS (OBDII)		
Classification: IM	PASSED	Inspection Fee: \$23.75
Electronic Authorization Number: 017		E-Auth. Fee: \$6.25
Date: 04/29/2016		Window Tinting Fee: \$0.00
		Total Fees: \$30.00
Make: Chevrolet		Vehicle Type: Light Duty
Year:		Plate Number: YWA
Engine Size: 5700		Odometer Reading: 303485
Body Style: Pickup		Number of Cylinders: 8
VIN: 1GCEC14RXWZ		Type of Fuel: Gasoline
County:		Previous Odometer:
TIN: 812610409757		Motor Vehicle Dealer Number:



Fee Schedule



1. The inspection fee for performing an inspection of a vehicle applies when an inspection is performed, regardless of whether the vehicle passes the inspection. The fee for an electronic inspection authorization applies when an electronic inspection authorization is assigned to a vehicle.
 - a) The inspection fee for an OBD II inspection (\$23.75) is negotiable and can be waived at the discretion of the inspection station.
 - b) The electronic inspection authorization fee (\$6.25) is mandated by North Carolina General Statute 20 – 183.7 and cannot be waived.

Fee Schedule (Continued)

2. A vehicle that is inspected at an inspection station and fails the inspection is entitled to be re – inspected at the same station at anytime within 60 days of the failed inspection without paying another inspection fee.



Warranty Information

(Performance Warranty)

Manufacturers have been required by federal law to provide emissions control warranty coverage for vehicles since 1972. There are two federal emissions control warranties offered.

1. Performance Warranty:

The Performance Warranty covers repairs, which are required during the first 2 years or 24,000 miles of vehicle use, because the vehicle failed an emissions test. A customer would be eligible for this warranty protection when the following conditions apply.

The 2-year, 24,000-mile performance warranty does not affect the 3 years or 70,000-mile state emissions exemption requirements. No vehicles with in the 3 most recent model years with less than 70,000 miles will require an emission inspection.

Warranty Information

(Performance Warranty)

- a) The car or light duty truck fails an approved emissions test; and
- b) The vehicle is less than two years old and has less than 24,000 miles; and
- c) The vehicle is required to be repaired in order to pass inspection requirements; and
- d) The test failure does not result from misuse of the vehicle or a failure to follow the manufacturers' written maintenance instructions; and
- e) The vehicle was presented to a warranty-authorized manufacturer representative, along with evidence of the emissions test failure, during the warranty period.



Warranty Information

(Design and Defect Warranty)

2. Design and Defect Warranty:

The Design and Defect Warranty covers repair of emissions related parts, which become defective during the warranty period. This warranty is applicable when the following conditions apply.

- a) An emissions control or emissions related part, or specified major emissions control component, fails because of a defect in materials or workmanship, as long as the vehicle has not exceeded the warranty time or mileage limitations for the failed part.
- b) Coverage may vary depending on the type of vehicle being tested. To determine the length of warranty coverage that applies to specific vehicles, look for the emissions warranty information in the owner's manual or warranty booklet.

Major Emissions Control Components



3. Major Emissions Control Components:

There are two specified major emission control components, covered for the first 8 years or 80,000 miles of vehicle use on 1995 and newer vehicles.

a) Catalytic Converters



b) The electronic emission control unit or computer (ECU)



Waivers

Waivers are available for vehicles unable to pass an emissions inspection test and are granted by authorized NCDMV personnel. A vehicle receiving a waiver is exempted from meeting the full requirements of the emissions test portion of the inspection. There are five types of waivers issued by NCDMV.

- a) Repair Waivers
- b) Non – Communication Waiver
- c) Not – Ready Re-inspection Waiver
- d) Not – Ready Initial Waiver
- e) Damaged Data – Link Connector Waiver

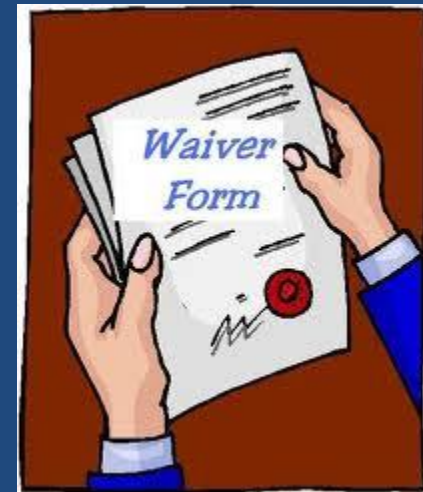

Inspections conducted for a vehicle that has been issued a waiver, should be completed under “Re-inspection with Waiver”.

Repair Waivers

1. Repair Waivers may be issued when a vehicle passes the visual component and safety inspection, but fails the OBD II emissions inspection because of an OBD II emissions related failure. In order for a repair waiver to be granted, the following procedure must be followed.
 - a) Before repairs are conducted, the vehicle must be inspected on the emission analyzer and fail the inspection due to an OBD II related failure.
 - b) Documented qualifying repairs costing at least the waiver amount must be made to the vehicle in order to correct the cause of the OBD II related failure. The waiver amount is mandated at \$200.00.
 - c) Within 60 days of the initial inspection, the vehicle must be tested on the emissions analyzer and again fail the inspection for an OBD II emission related failure.

Repair Waivers

The following repairs and their cost cannot be included or considered when determining whether the cost of repairs made to a vehicle equals or exceeds the mandated waiver amount of \$200.00.

1. Repairs covered by a warranty that applies to the vehicle.
2. Repairs needed as a result of tampering with an emission control device of the vehicle.
3. Cost associated with labor made by an individual who is not engaged in the business of repairing vehicles.

Non-Communication Waivers

2. A Non-Communication waiver can be issued when a vehicle passes the visual component and safety inspection but fails the OBD II emissions inspection because it failed to communicate with the approved state analyzer. For a waiver to be granted, the following procedure must be followed.
 - a) The customer should be provided with the failure receipt and the secondary page showing the diagnostic trouble codes indicated (if any).
 - b) The customer should be advised to go to the local DMV License & Theft Bureau office for assistance.
 - c) DMV personnel will test the vehicle using an independent scan tool.

Non-Communication Waivers (Continued)

- d) If the vehicle fails to communicate with the scan tool, a non-communication waiver cannot be issued and the vehicle will need to be taken in for repairs.

- e) IF the vehicle communicates with the scan tool, DMV personnel will issue a Non-Communications waiver and the customer will be directed to return to the original inspection location.

Non-Communication Waivers (Continued)

A Non-communication waiver will not be issued if any of the following circumstances exist.

- a) The vehicle fails to communicate with the independent scan tool.
- b) The vehicle would fail the inspection for any other reason.

The vehicle must communicate with the analyzer or the License and Theft Bureaus independent scan tool. No waiver can be issued for a vehicle that does not communicate with an analyzer or does not communicate License and Theft Bureaus independent scan tool. Federal Guidelines require fail codes to be verified.

**What We've Got
Here Is Failure To
Communicate**

Not-Ready Re-inspection Waiver

3. DMV personnel may issue a Not – Ready Re-inspection Waiver when the vehicle is rejected from multiple inspection attempts, only when the following conditions are met. (Additional requirements may be imposed at the discretion of DMV personnel.)
 - a) The vehicle was not ready rejected after repairs were conducted for failing the OBD II inspection.
 - b) The customer can produce a vehicle inspection report showing a failure of an OBD II related issue.
 - c) The customer can produce repair receipts showing qualified documented repairs (and their cost) to the OBD II system.

Not-Ready Re-inspection Waiver (Continued)

- d) The customer can produce multiple not ready rejection inspection attempts from a state approved analyzer.
- e) The customer can produce copies of the manufacturers recommended drive cycle that was conducted if the re-inspection took place on the same date of the repairs.
- f) The customer's documentation shows a reasonable mileage change between the first and last inspection.

Not – Ready Initial Waiver

4. DMV personnel may issue a Not – Ready Initial Waiver when the vehicle is rejected from multiple inspection attempts, only when the following conditions are met. (Additional requirements may be imposed at the discretion of DMV personnel.)
 - a) The vehicle was not ready rejected during the initial inspection attempt.
 - b) The customer can produce multiple not ready rejection inspection attempts from a state approved analyzer.
 - c) The customer can produce the repair receipts (if applicable)
 - d) The customer can produce the manufacturers recommended drive cycle if the re-inspection attempts took place on the same date of any repairs or must be documented by a reasonable mileage change between the first and last inspection over multiple days.

Damaged Data – Link Connector

The Damaged Data – Link Connector Waiver may be issued to bypass the OBD II test to gain access to the Safety / Tamper portion of the inspection. This waiver is issued as a last resort for special situations when other waivers are not appropriate, and the damage cannot be repaired.



Exemptions

Exemptions are available for vehicles unable to pass or unable to obtain an emissions inspection test as detailed below. There are three types of exemptions issued by NCDMV.

- a) Out of County Exemptions
- b) Out of State Exemptions
- c) Parts Exemption



Out of County Exemptions

1. An Out of County Exemption may be issued for vehicles registered in an emissions county when it has been determined that the vehicle is principally garaged and operated outside a county subject to emissions inspections. A safety only inspection is required on these vehicles. The exemption expires at the end of the registration period.



Out of State Exemptions

2. An Out of State Exemption may be issued for vehicles registered in an emissions county when it has been determined that the vehicle is principally garaged and operated outside the state. When an Out of State Exemption has been issued, the vehicle is exempted from all inspection requirements. The exemption expires at the end of the registration period.



Parts Exemption

3. Parts Exemptions are issued for vehicles that are missing emissions components that are not available from any source. This exemption only applies to the emissions component or components identified on the exemption and the vehicle must pass all other inspection requirements. – The License and Theft Bureau will confirm the availability of the part.

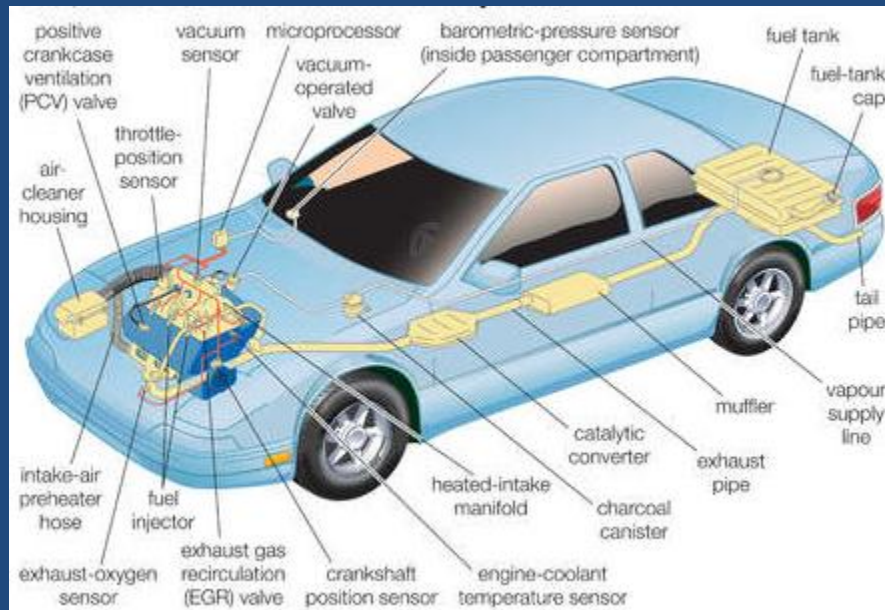

Smog Parts Phone # 559-636-7450
800-544-4357

19A NCAC 03D .0545

INVESTIGATION/AUDIT/SAFETY OR EMISSIONS INSPECTION STATIONS

- (a) **Complaints To Be Investigated:** All complaints received by the Commissioner about any inspection station shall be investigated for the purpose of determining whether there has been a violation of the Rules of this Section and applicable General Statutes.
- (b) **Appropriate Enforcement Action To Be Taken:** When it appears from any investigation that the inspection law has been violated by an inspection station or its agents or employees, or by a self-inspector, the Commissioner shall take the appropriate enforcement action, which may include suspension or revocation of the station's license and inspector certifications.
- (c) **Report of Undercover Investigation:** Periodic checks shall be made by undercover officers of the Division of Motor Vehicles routinely and upon receipt of complaints to determine compliance with inspection laws. If violations are detected, administrative action shall be taken by the Division of Motor Vehicles against the licensed station and the inspection mechanic.
- (d) When an authorized agent of the Division of Motor Vehicles detects a violation, he or she shall require the owner or operator to discontinue all inspections and operations until he or she is in compliance and approved by the Division of Motor Vehicles Inspector.
- (e) **Compliance Audit:** A DMV Inspector shall audit a station's compliance with the Rules of this Section. Violation of the equipment requirements shall result in lockout of the inspection analyzer. Lockouts shall remain in effect until the issue has been brought into compliance.

Violations

The civil penalty schedules established in North Carolina General Statutes are required when a violation has occurred. The schedule categorizes emissions violations into three different types.

- a) Type I
- b) Type II
- c) Type III

Type I Civil Violations

1. Type 1 violations are the most severe civil violations as they directly affect the emissions reduction benefits. They include:
 - a) Issue an emissions electronic inspection authorization on a vehicle without performing an emissions inspection of the vehicle.
 - b) Issue an emissions electronic inspection authorization on a vehicle after performing an emissions inspection of the vehicle and determining that the vehicle did not pass the inspection.

Type I Civil Violations

- c) Using a test-defeating strategy when conducting an emissions inspection by changing the emissions standards for a vehicle by incorrectly entering the vehicle type or model year, or using data provided by the on-board diagnostic (OBD) equipment of another vehicle to achieve a passing result.
- d) Allowing a person who is not licensed as an emissions inspection mechanic to perform an emissions inspection for a self-inspector or at an emissions station.
- e) Perform a safety-only inspection on a vehicle that is subject to both a safety and emissions inspection.

Type II Civil Violations

2. Type 2 violations are considered less severe than type 1 violations but might adversely affect the emissions reduction benefits. They include:
 - a) Using the identification code of another to gain access to an emissions analyzer or to equipment to analyze data provided by on-board diagnostic (OBD) equipment.
 - b) Keeping compliance documents in a manner that makes them easily accessible to individuals who are not inspection mechanics.

Type II Civil Violations

- c) Issue a safety only electronic inspection authorization on a vehicle or an emissions electronic inspection authorization on a vehicle that is required to have one of the following emissions control devices but does not have it:

1) Catalytic Converter	5) Unleaded Gas Restrictor
2) PCV Valve	6) Gasoline Tank Cap
3) Thermostatic Air Control	7) Air Injection System
4) Oxygen Sensor	8) EGR Valve

Type II Civil Violations

- d) Issue a safety electronic inspection authorization or emissions electronic inspection authorization on a vehicle without performing a visual inspection of the vehicles exhaust system and checking the exhaust system for leaks.
- e) Impose no fee for an emissions inspection of a vehicle or the issuance of an emission electronic inspection authorization or impose a fee for one of the actions that differs from the amount allowed by North Carolina General Statute 20-183.7.

Type III Civil Violations

3. Type 3 Violations are considered technical violations and don't normally have an adverse affect on the emissions reduction benefits. They include:
 - a) Fail to post an emissions license issued by the Division.
 - b) Fail to post emissions information required by federal law to be posted.
 - c) Fail to put the required information on an inspection receipt in a legible manner.

Fines and Suspensions

In any case where the Division determines that a violation of the Type 1, 2, or 3 civil violations has occurred, it must take the following action.

a) Type 1. - Emissions Station

For a First or second Type 1 violation, assess a civil penalty of \$250.00 and suspend the license of the business for 180 days. For a Third or subsequent Type 1 violation within three years, assess a civil penalty of \$1,000 and revoke the license of the business for Two years.

b) Type 1. - Emissions Mechanic

For a First or second Type 1 violation, assess a civil penalty of \$100.00 and suspend the mechanics license for 180 days. For a Third or subsequent Type 1 violation within seven years by an emissions mechanic, assess a civil penalty of \$250.00 and revoke the mechanic's license for Two years.

Fines and Suspensions (Continued)

c) Type 2. - Emissions Station.

For a First or second Type 2 violation, assess a civil penalty of \$100.00. For a Third or subsequent Type 2 violation within three years, assess a civil penalty of \$250.00 and suspend the license of the business for 90 days.

d) Type 2.- Emissions Mechanic

For a First or second Type 2 violation, assess a civil penalty of \$50.00. For a Third or subsequent Type 2 violation within seven years by an emissions mechanic, assess a civil penalty of \$100.00 and suspend the mechanic's license for 90 days.

Fines and Suspensions (Continued)

e) Type 3 - Emissions Station or Mechanic.

For a First or second Type 3 violation, send a Warning letter. For a Third or subsequent Type 3 violation within three years by the same emissions license holder, assess a civil penalty of \$25.00.

PENALTY

Mechanic Training

An emission inspection mechanic whose license has been suspended or revoked must retake and successfully complete the required course before the mechanic's license can be reinstated. Failure to successfully complete this course continues the period of suspension or revocation until the course is completed successfully.



Station and Self-Inspector Responsibility

It is the responsibility of an emissions inspection station and an emissions self-inspector to supervise the emissions mechanics it employs. A violation by an emissions inspector mechanic is considered a violation by the station or self-inspector for whom the mechanic is employed.

Responsible—definition

- o ***Responsible:*** 1) liable to be called on to answer; liable to legal review or in case of fault to penalties; 2) able to answer for one's conduct and obligations; able to choose for oneself between right and wrong... (Webster's Ninth New Collegiate Dictionary)

Criminal Infractions

A person who does any of the following commits an infraction and, if found responsible, is liable for a penalty of up to \$50.00.

- a) Operates a motor vehicle that is subject to inspection on a highway or public vehicular area in the State when the vehicle has not been inspected in accordance with General Statutes.
- b) Allows an electronic inspection authorization to be issued to a vehicle owned or operated by that person, knowing that the vehicle was not inspected before the electronic inspection authorization was issued or was not inspected properly.
- c) Issues an electronic inspection authorization to a vehicle, knowing or having reasonable grounds to know that an inspection of the vehicle was performed improperly.
- d) Alters the original certified configuration or data link connectors of a vehicle in such a way as to make an emissions inspection by analysis of data provided by on-board diagnostic (OBD) equipment inaccurate or impossible.

Criminal Felony Violations

A person who does any of the following commits a Class I Felony per NCGS 20-183.8 (c)

3) Buys, sell, or possess an electronic inspection authorization other than as the result of either of the following:

a. Having a license as an inspection station, a self-inspector, or an inspection mechanic and obtaining the electronic inspection authorization from the Division in the course of business.

b. A vehicle inspection in which the vehicle passed the inspection or for which the vehicle received a waiver.

4) Solicits or accepts anything of value in order to pass a vehicle that fails a safety or emissions inspection.

5) Fails a vehicle for any reason not authorized by law.

Clean Scanning

Clean scanning is defined as a fraudulent inspection through the manipulation of testing procedures to pass a vehicle that:

- a) Has failed a previous test, or
- b) Is not able to be tested due to too many emissions monitors set as not ready, or
- c) To create a passing result for a vehicle that may not even be on site.

Charlotte Auto Repair Auto Shop Owner Is Sentenced And Fined For Violating The Clean Air Act

CHARLOTTE, N.C. – Today, U.S. District Judge Frank D. Whitney sentenced Jamal Saymeh, 59, of Charlotte, N.C., to 12 months and one day in prison followed by two years of supervised release for violating the Clean Air Act, by fraudulently coding over 15,000 vehicles that would have otherwise failed the required State emissions inspection, announced Dena J. King, U.S. Attorney for the Western District of North Carolina. Judge Whitney also ordered Saymeh to pay a \$1,202,288.50 fine and \$82,026 in restitution to the State of North Carolina.

Contact Information

The License & Theft Bureau is divided into seven districts as indicated. The contact information for each district is as follows:

District 1	Phone: Fax:	(252) 999-7500 (252) 752-6926	4651 North Creek Dr. Greenville, NC 27834
District 2	Phone: Fax:	(910) 486-1331 (910) 486-1322	4705 Clinton Rd. Fayetteville, NC 28303
District 3	Phone: Fax:	(984) 920-8450 (984) 920-8480	3231 Avent Ferry Road Raleigh, NC 27627
District 4	Phone:	(743) 222-6000	2391 Coliseum Blvd Greensboro, NC 27403
District 5	Phone: Fax:	(336) 767-8808 (336) 767-4781	470 W. Hanes Mill Rd. Suite 103 Winston Salem, NC 27105
District 6	Phone: Fax:	(704) 331-4500 (704) 331-5431	12101 Mt. Holly Huntersville Rd. Charlotte, NC 28078
District 7	Phone: Fax:	(828) 782-9640 (828) 251-6110	1624 Patton Avenue Asheville, NC 28806

Conclusion

During this block of instruction, we have discussed the negative effects of air pollution and its possible impact on our future. Although many debates can be held over the validity of reduction methods, no one can debate the need for such programs, as the evidence is overwhelming. Through proper maintenance of our vehicles, we are taking a proactive approach that helps the environment, increase our fuel mileage and extends the life of our vehicles. With all these positives, willful participation should be easily obtained.

Closing Statement

Motor vehicles are the largest source of air pollution in the nation and inspection maintenance programs are one of the most important tools for reducing smog and toxic air pollutions. The OBD II inspection offers many benefits to the consumer, the technician and the environment. It provides for an accurate diagnostics that leads to effective, durable repairs and a shorter inspection time. It offers an early vehicle maintenance opportunity that leads to greater fuel efficiency and reliability. North Carolina's OBD II inspection program has been highly effective in reducing the amount of pollution from mobile sources. With continued increase in public awareness, and the reduction benefits of properly maintained vehicles, we can ensure the continued success of our efforts for years to come.

Thank you for taking the time to attend
class at this Community College!

